



***UL1AB and UL1FG
(ABS and Fiberglass)
Assembly Instructions***

***UL-72 Pocket Mechanic
UL-10 Wiggins
UL-125 Wild Fire***

Last revised: 1/27/01 AMK

SAFETY NOTES

WARNING! Electric hydroplanes are NOT toys. Improper use may be hazardous to swimmers, boaters, and other model boats, as well as to the operator!

This product is not recommended for use by minors without close adult supervision. It is strongly recommended that the user be a member of one of the national model boating organizations (listed below) and that he/she adhere to all safety rules of that organization.

This model is intended only for use by experienced boaters.

SAFETY IS JOB 1

NEVER USE ALCOHOL OR OTHER DRUGS WHICH MAY IMPAIR YOUR REFLEXES. Over-the-counter medicines which warn of driving or operating machinery should be avoided.

DO NOT operate your model boat without adult assistance. If anything should happen, you want someone to help you out!

DO NOT operate your model boat while people are swimming or wading in the water. These models travel at a high speed, and the impact of the boat or the spinning propeller may cause irreparable damage to flesh!

DO NOT put your fingers near the propeller while the batteries are in the boat! Serious injury may result.

DO NOT swim to retrieve a stalled boat. Numerous people have drowned trying it. Don't make their mistake!

DO NOT operate your boat when it is dark. You should be able to see your boat clearly when it is at least 200 feet away from you.

DO solicit advice from the owner of your local hobby shop. And buy from him to keep him in business! He may know of a club or other boaters who would like to form a club.

DO subscribe to a model boating magazine. The local hobby shop and/or club members can recommend some.

DO take reasonable and proper precautions to protect spectators and other boaters. It is YOUR responsibility to watch for THEM!

DO keep spectators at least 15 feet from any operable boat. NEVER allow a spectator in the water while model boats are operating, and NEVER operate model boats when people are swimming, boating, etc.

DO wear closed-toes shoes for protection when boating. Your pitman should wear closed-toe shoes as well.

DO use a frequency identifier flag with your transmitter. Frequency flags are usually supplied with your radio, and are also available at good hobby shops.

DO perform a range check before running. Range check instructions should be supplied with your radio system.

DO keep your running course at least 50 feet from shore. This will provide you with a safety margin in case of problems.

DO have your name, address, and phone number externally on your transmitter. This will help you make sure you use the correct radio when they are impounded, and will make it easy to return should you forget it somewhere.

DO join a local club to benefit from the experience more mature modelers have.

DO join a national or international model boating organization. Check with your local club to see what is recommended locally. If you cannot find a club which is active in your area, contact each of the following organizations to ask about local members and clubs in North America:

NAMBA International
1615 Halley Street
San Diego, CA 92154
619-424-6380
www.namba.com

IMPBA
5855 S. State Road 9
Fountaintown, IN 46130

www.impba.com

In Europe contact Electra at either of the following addresses or on the Internet at <http://www.astec44.freemove.co.uk/electra.htm>

Electra
%Allan Shillitto
6 Stickland
Clevedon
North Somerset
BS21 5EX
info@astec44.freemove.co.uk

Electra
%Alan Egleton
262 Cressex Road
Booker
High Wycombe
Bucks HP12 4UF
Alan@egletona.freemove.co.uk

IF POSSIBLE, provide a fence around your pit area, as well as those places on the course which are close to the water, especially where there is a gentle sloping beach which a fast-moving boat can run onto.

If your boat runs aground, you should inspect it thoroughly and test it to verify that nothing was damaged. Propellers, rudders, skid fins, and servo actuation are frequent failures.

DISCLAIMER

Due to the fact that these boats are intended for use **ONLY** by experienced modelers, and that organized competition will frequently cause racers to push their equipment well beyond the design limits, RC-Hydros.com is **NOT** liable for **ANY** misuse of this product. Assembly or operation of this product implies acceptance of this policy.

SPECIFICATIONS

Length: 24.5" at deck (622mm)
Width: 11" (330mm)
Weight: 40 oz (Ready to run except cells) (2.2 kg) ABS hull with Cordite motor. The ABS and fiberglass hulls weigh virtually the same and are equally strong. The ABS is much easier to build and finish, but fiberglass has "snob appeal."

Sport Recommendations:

Motor: Graupner 700BB (included in GR1157 Hardware Package)
Propeller: Stock Graupner plastic propeller
Batteries: (2) six-cell "stick" packs available from your local hobby shop, with a variety of brand names. We recommend a minimum of 1500MAH packs for adequate runtime. For longer runtime, we recommend you visit Hill's RC (<http://sjshill.hypermart.net>) and tell them we sent you.
Speed Control: Any 12-cell capable speed control capable of 60 Amps continuous (our SC-2 AsTec ESC, or Hughey mechanical, as well as others.)
Hardware: GR1157 Hardware Package

Club Racing Recommendations:

Motor: Graupner 700BB, Graupner 770 (Cobalt), or Astro 25 (Cobalt)
Propeller: Octura X438-X450 (depends on motor) (requires adapter with GR1157)
Batteries: (2) six-cell "matched" packs available from your local hobby shop or various online sources including Hill's RC (<http://sjshill.hypermart.net>).
Speed Control: Any 12-cell capable speed control capable of 60 Amps continuous (our SC-2 AsTec ESC, or Hughey mechanical, as well as others.)
Hardware: GR1157 Hardware Package or a Fullers, Octura, or BBY Racing 3/16" setup

Pro Racing Recommendations:

Motor: FDM Cordite, 4-Turn, or Aveox
Propeller: X642-X448 (depends on setup)
Batteries: (2) six-cell "Pro" matched packs available from your local hobby shop or various online sources including Hill's RC (<http://sjshill.hypermart.net>).
Speed Control: Any 12-cell capable speed control capable of 60 Amps continuous (our SC3, AsTec ESC, or Hughey mechanical, as well as others.)
Hardware: Fullers, Octura, BBY Racing, or your own custom setup.

ASSEMBLY

General Instructions

This boat is intended for use by experienced modelers. It is assumed that, as an experienced modeler, you know the correct handling procedures for the materials you will need.

An experienced modeler does not necessarily imply an experienced racer, nor does an experienced racer imply and experienced modeler! The instructions are written to assemble a sport or mildly hopped-up boat. It is our experience that racers don't follow directions, so not much time was spent trying to address their needs. If you are a racer and have questions, e-mail us at support@rc-hydros.com.

As a reminder, a few of the things you will need are:

Dust mask – fiberglass, wood, and plastic dusts are not good for your nose, lungs, mouth, etc.

Eye protection – dust and metal or other particles come with the boat, and will be generated by the modeler during construction. Your eyesight is worth the minor discomfort!

Rubber gloves – keep the fine shards of fiberglass out of your skin by wearing rubber gloves whenever you handle the model. For ABS, be aware that the cut edges of the plastic can be quite sharp.

Ventilation – many glues, paints, etc. have harmful vapors. Make sure your building area is properly ventilated. Cyanoacrylate and epoxy may both damage your nose, throat, and lungs - this model isn't worth your future health! Work in a well-ventilated area!

Most assembly is done using thin cyanoacrylate glue. This is referred to as "CA" in the instructions below. Other times epoxy is used. Please follow the directions, using the correct adhesive as noted. CA is also referred to in some locales as "super glue."

The UL1 is intended to be built using the Graupner "Taifun" drive assembly, available from either RC-Hydros.com or from Hobby Lobby. The part number for both places is GR1157, and must be ordered separately (it is available at a discount as part of UL1ABC package). Additional upgrades are being made available all the time – visit the web site for availability.

Also available separately is a vinyl decal set for making your boat look like the real boat. Order part number UL72VIN for the Pocket Mechanic, UL125VIN from RC-Hydros.com for the Wild Fire, or UL10VIN for the Earl's/Wiggins. (Note – please download the appropriate vinyl manual before ordering).

Step-by-step assembly

- 1) Wash the boat inside and out with mildly soapy water to remove any dust left from the manufacturing process. It is recommended that you use rubber gloves to avoid getting splinters into your hands.

After washing, start sanding the exterior. You want to make the hull as smooth as possible for optimum performance and appearance. It is best to use a mildly soapy water and a variety of grits of sandpaper (starting with about 220 grit). Some modelers prefer to finish the boat to the primed stage prior to beginning internal construction, others wait until all assembly is complete. The choice is yours, but it is really, really important that you do at least some of the finishing now!

On ABS and fiberglass hulls, there are occasionally small voids or dimples. These can be removed by sanding, using Squadron Putty (from the plastic section of the hobby shop) or auto body filler (from the auto store) to fill the holes. Another method which is sometimes used on the glass hulls is to mix epoxy with micro balloons, using this as a filler.

Also, it is recommended that the join edges be sanded back to a smooth contour between deck and hull, removing the excess flange from the deck portion. A smooth edge will not only look better, but it will improve performance especially in windy conditions.

After you are done filling and sanding, you are ready to begin assembly.

- 2) Draw a centerline lengthwise down the tunnel of the boat.
 - a) Make a mark 3 3/4" from the inside of the right sponson tunnel at the transom.
 - b) Make another mark near the front of the center section, also 3 3/4" from the right sponson.
 - c) Connect the two marks, to define the centerline of the hull. *This is not necessarily the exact centerline, but it will be referred to as such.*
- 3) Make cross-marks on the centerline at the following distances from the transom: 2 1/2", 5 1/2", 10", 13 3/4". The 5 1/2" point is very close to or on the back edge of the engine well. See drawing on next page.

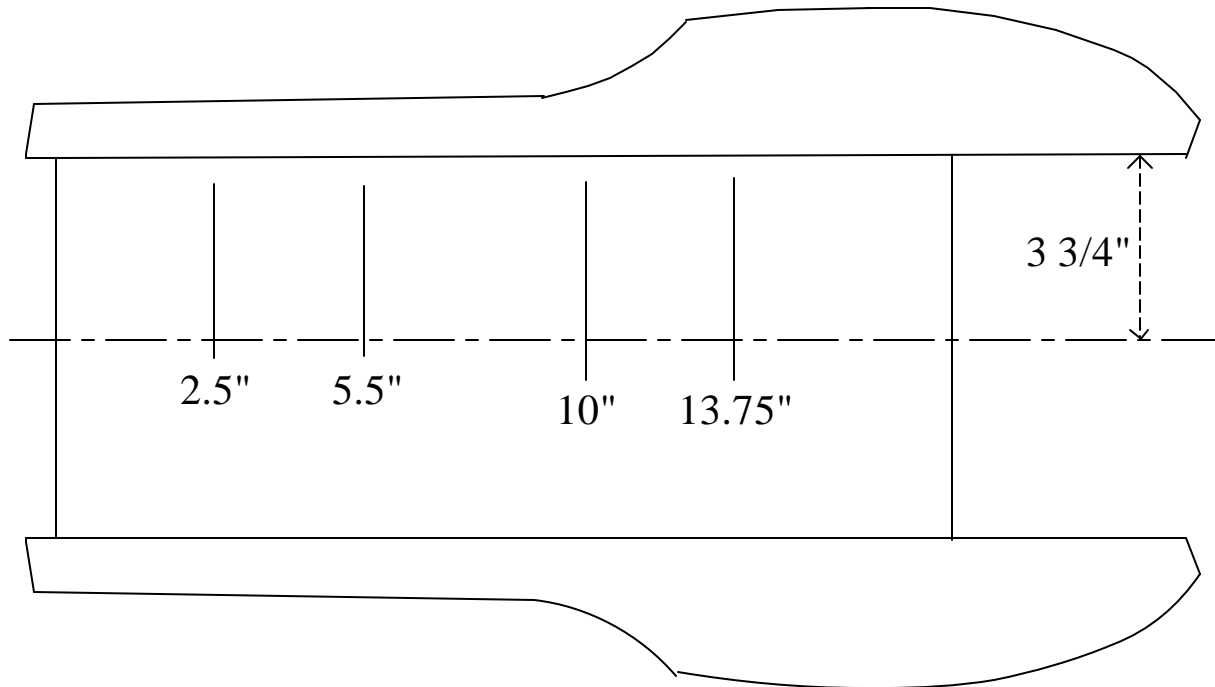

- 4) Make lines $3/16$ " off the centerline on either side, from the $2\frac{1}{2}$ " to $5\frac{1}{2}$ " marks. This defines a box which will later be cut out to allow the installation of the Graupner stuffing box. We will call this "Area A."

If you are setting up your boat for racing, it is wise to offset the prop shaft at an angle. Our racing boats are set such that the prop is about $1/2$ " to the left of the boat from center. This causes the hole to be offset slightly. NOTE: The Graupner hardware is not intended for serious racing! Racers – send an e-mail for recommendations.

- 5) Make lines $5/8$ " off the centerline on either side, between the 10" and $13\frac{3}{4}$ " marks. This defines a box which will be the glue area for the Graupner motor mount. We will call this "Area B." Whether you are racing or not, Area B does not change. If you intend to use an Astro Flight motor, you will need to devise your own motor mount, as the Graupner mount does not accept the large brush hoods. We strongly recommend the use of a Cordite motor for racing this boat.

For racers who chose to not purchase the Graupner hardware kit, we recommend using a plywood motor mount which puts the motor very close to the bottom of the boat. The "firewall" portion of this mount is available upon request. This motor mount will replace step 6.

- 6) **FIBERGLASS:** Use coarse (80 grit) sandpaper to roughen the bottom of the motor mount. Smear some well-mixed 30-minute epoxy on the bottom of the mount, and place inside the boat using the lines for Area B as a guide. NOTE: it may be useful to use CA glue to tack the mount into position so the epoxy can cure without the motor mount moving.

ABS: Use coarse (80 grit) sandpaper to slightly roughen the bottom of the motor mount. It is often wise to drive several 1/8" diameter holes in the bottom of the mount, as the plastic for this does not always bond well to the glue. Slightly roughen the interior of the hull with some 240 grit paper. Use either an epoxy such as JB Weld (preferred) or thick

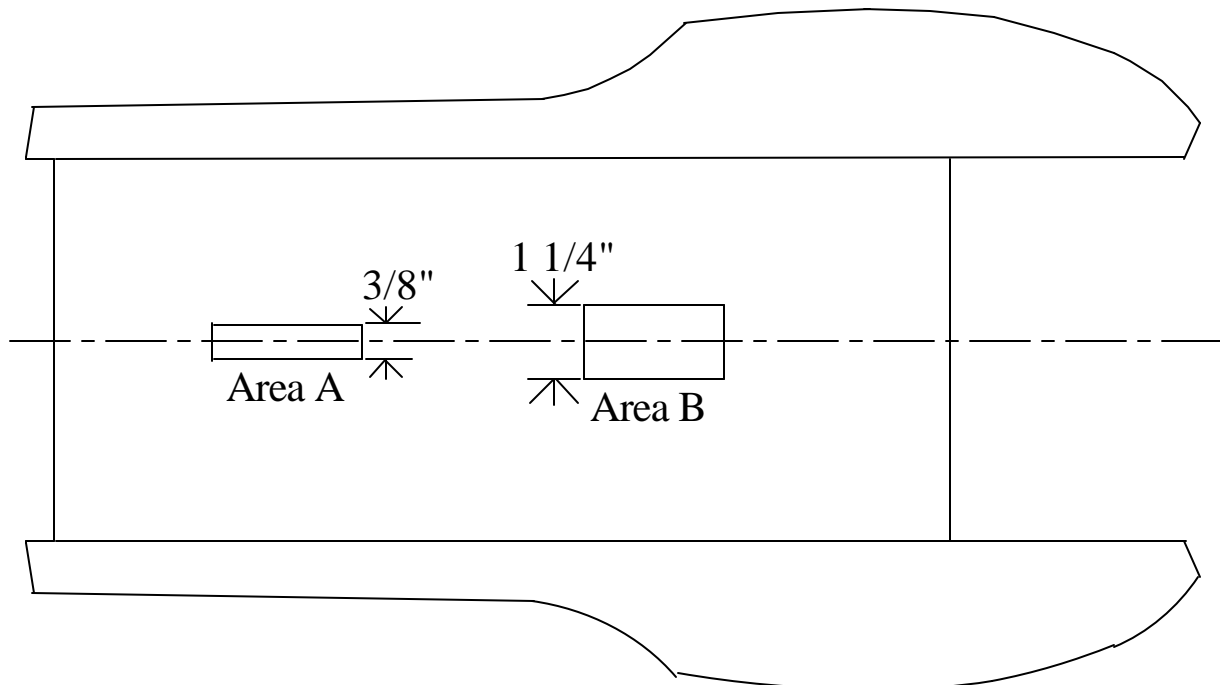

CA to secure the motor mount into the hull, using the lines of Area B as a positioning guide.

ALL: It is best that the motor mount be set to be parallel to the driveshaft. If you are using an offset stuffing box, you should keep this in mind as the Area B lines are not parallel to the driveshaft.

- 7) **FIBERGLASS:** While the epoxy cures (allow 1 hour for 30-minute epoxy, just to be more sure), sand the wing and fin surfaces smooth with 220 grit or finer paper. It is recommended that you work on the wing parts as you have time during the remainder of the assembly. The recommended method for finishing the wood surfaces is to use a good-quality sanding sealer and balsa filler such as those in the Aero Gloss brand line from Pactra, lightly wet sanding with 400 grit paper between coats.

While the JB Weld cures (allow extra time, just to be more sure), sand the vertical fin surfaces smooth with 220 grit or finer paper. It is recommended that you work on the wing parts as you have time during the remainder of the assembly. The recommended method for finishing the wood surfaces is to use a good-quality sanding sealer and balsa filler such as those in the Aero Gloss brand line from Pactra, lightly wet sanding with 400 grit paper between coats.

- 8) **FIBERGLASS: READ STEP 9 NOTE BEFORE CUTTING!** After the glue from Step 6 is cured, use a motor tool with a cutoff wheel to cut the Area A out of the hull. You may wish to round the ends of the cut in order to allow them to more closely match

the profile that the stuffing box will have. This will minimize the need to add filler material later. If you are using an off-center driveshaft, be sure you cut appropriately.

ABS: READ STEP 9 NOTE BEFORE CUTTING! After the glue from Step 6 is cured, use a sharp hobby knife to cut the Area A out of the hull. You may wish to round the ends of the cut in order to allow them to more closely match the profile that the stuffing box will have. This will minimize the need to add filler material later. If you are using an off-center driveshaft, be sure you cut appropriately.

- 9) Assemble the drive train components: bushings, driveshaft, motor coupler, motor, and motor mount (already installed in boat). Set your stuffing box in place so that the motor end does not have any misalignment; the flexible coupler should naturally bend to accept the motor driveshaft. Set the rear end of the stuffing box so it is about 5/16" below the transom, and so that it extends about 1/2" past the transom. The actual position fore/aft will be determined by the other drive components, and this is the reason for you to assemble the system completely at this point.

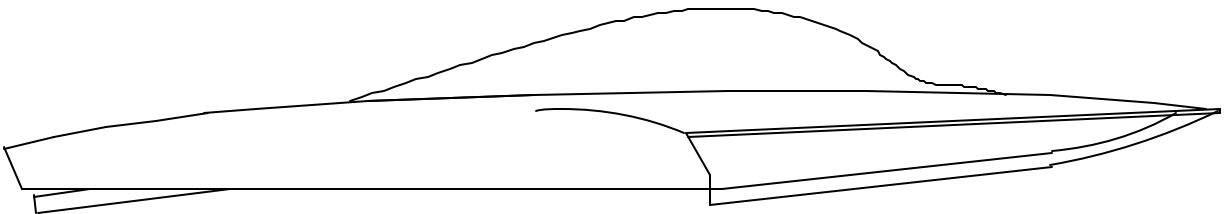

***NOTE:** If you are using a high-power motor (other than the Graupner 700 BB which comes with the GR1157), you should set the driveshaft at a lower angle. Our racing hulls (using custom hardware) are set so the end of the driveshaft, the center of the driveshaft is 1/16" below the lowest point of the sponsons at the transom. This also allows the use of larger props on the 700BB motor, but it changes the position of the Area A cut-out.*

- 10) With the drivetrain in place, tack it in position using some gap-filling CA and accelerator. Be careful not to use too much CA – you want to use epoxy to make the joint strong. The CA is just a tool to hold alignment.

If you are building this boat for racing or plan to use higher-power motors, you should at this time add two lengths of fiberglass or graphite tubing to extend from the forward cross-brace (in front of the motor area) to the balsa bulkhead or radio box. These will tie the motor mount, stuffing box, and hull together in order to make the boat stiffer. We recommend using fiberglass pushrods from Dave Brown Products for this purpose. These are available at your local hobby shop. Use epoxy for fiberglass hulls, or JB Weld or thick CA for ABS hulls.

- 11) **FIBERGLASS:** Use a thickened (with micro balloons) 5-minute epoxy to seal the opening around the stuffing box. If you have some glass cloth, it may be used to further strengthen the joint when applied inside the hull. **BE SURE TO KEEP THE DRIVETRAIN PROPERLY ALIGNED WHILE THE EPOXY CURES!**

ABS: Use a silicone-based sealant to fill the hole around the stuffing box. **BE SURE TO CHECK THAT THE SEALANT YOU SELECT IS COMPATIBLE WITH PLASTICS.** More than one person has found out the hard way that they picked the wrong one!

- 12) Epoxy or CA scrap 1/8" plywood to fill the areas between the hull and the stuffing box. This will greatly strengthen the connection, and is very important for the hull to be

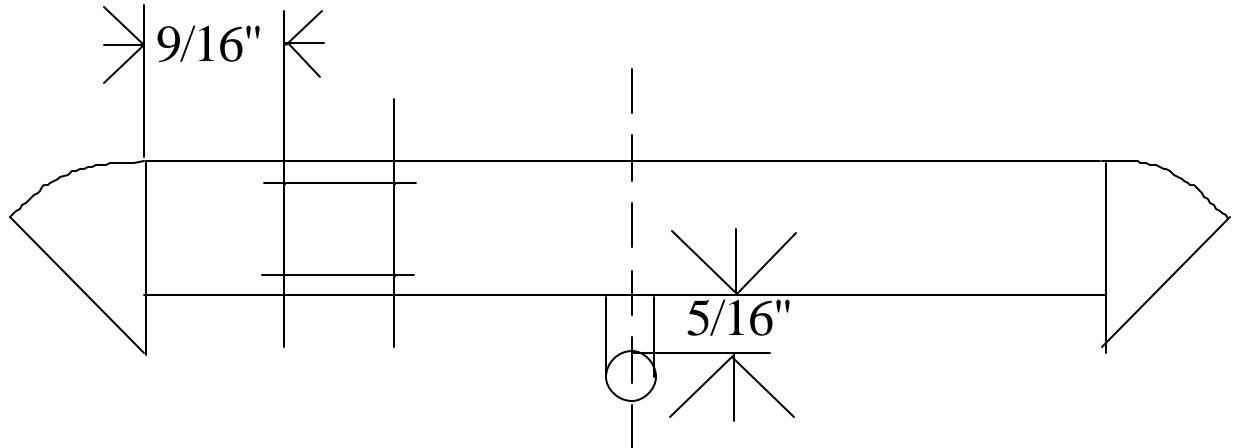

tunable for proper operation. It is also recommended that you use small pieces of fiberglass cloth.

- 13) Mount the Graupner skid fin bracket on the right sponson as far outboard as possible, angled so that the fin is about 5° from vertical. You will need to drill pilot holes for the mounting screws (use #4 self-tapping or 4-40 machine screws after tapping). This is a tight fit on the fiberglass boat, but on the ABS it is not a problem. You may want to remove a small amount of the skid fin mounting bracket in order to be able to set the fin higher on the sponson transom, in order to make the entire edge of the fin sharp where it is in the water.
- 14) Locate the rudder bracket on the transom to the left of the propeller, situated such that the mounting holes will be drilled about 9/16" from the outside edge of the transom (see figure above). Take some forethought for how to route the pushrod from the servo. The rudder mounting bracket will need to have new holes drilled into it to accept the smaller transom of the UL1. The two new holes should be drilled so that they pass through the cut-out section on the mounting side of the bracket.

The prototype fiberglass boats were modified by adding a fairing in front of the rudder bracket to make the lines smoother. While this is not scale, it does enhance appearance. If you are using an alternate rudder, this fairing becomes unnecessary.

- 15) **NO RADIO BOX:** Install your radio gear per your preferences. It is recommended that the rudder servo be located in the rear compartment as close as practical to the transom, and that a 1/8" ply doubler be added to the inside of the hull. This will help prevent flexing of the pushrod and hull under high stress (see drawing below).

RADIO BOX: Install the radio gear in the radio box at the appropriate locations. The actual position depends upon the type of radio equipment you use.

ALL: The radio receiver and receiver battery pack should be located in the same compartment as the servo.

Ideally, the antenna should exit the hull at a reinforced area. It is recommended that a piece of 1/8" ply 1" x 1" with rounded corners be added inside the deck at the place you wish to locate the antenna exit. This reinforcement provides the strength needed to hold

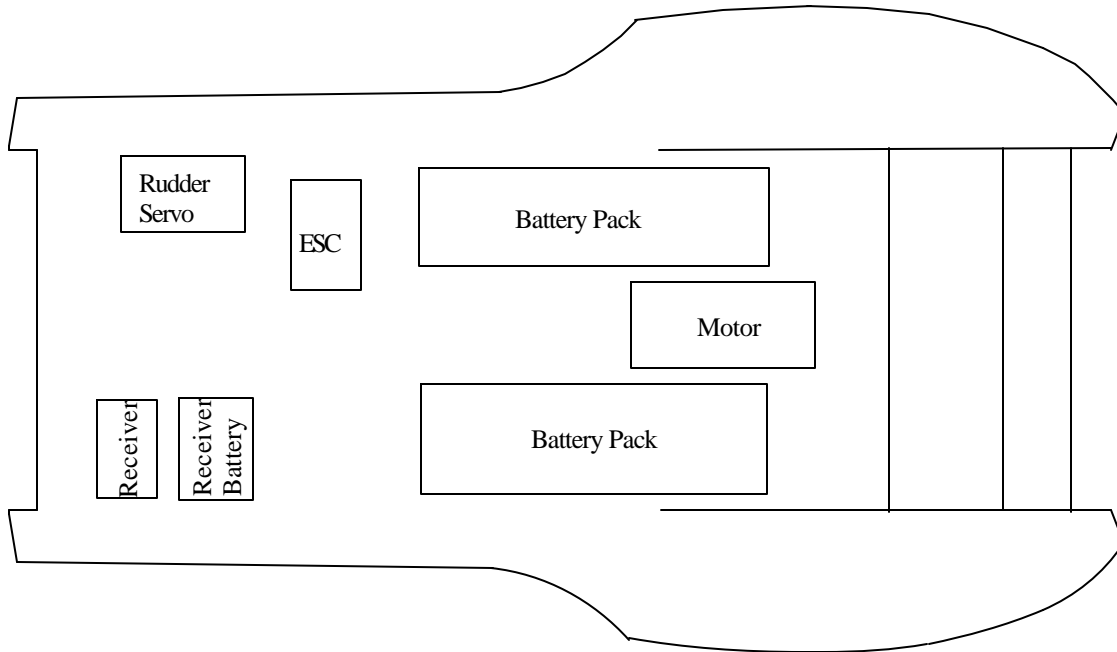

an antenna tube upright in racing conditions, and distributes the stress of possible impact across a larger area to help minimize any damage.

We did some experimenting with this, mounting the antenna in several locations. The most convenient turned out to be drilling a hole in the deck, in the flat area behind the cowling. This area was not reinforced, and it worked fine most of the time. In racing conditions, it could conceivably cause problems, but we have experienced none to date.

If you are using a removable antenna (such as Deans), it is recommended that the antenna be located as high on the boat as possible. There is no need to make it particularly accessible, in that case.

The ESC and batteries should be located in the forward compartment. The battery packs should be held in place with Velcro or similar hook-and-loop fasteners in order to allow positioning for best balance and performance. We recommend the Xipp 12-cell boat ESC available from Xipp Inc (www.xipp.com) for competition, or an Astro 212D for sport models.

FIBERGLASS: We recommend using a glueless Velcro from the local sewing store, which is then epoxied into the bottom of the hull, to hold the batteries.

ABS: Velcro-brand fastening with “peel-and-stick” adhesive on the back works quite well in a plastic boat. It is necessary to clean the plastic first using a fine sandpaper followed by rubbing alcohol. We have tried non-brand-name hook-and-loop fastenings, and found them to be unsatisfactory in the long run. Sometimes there’s a reason to buy name brand!

- 16) After you are satisfied with the location of all equipment, it is necessary to add the final touches – the wing surfaces. It’s important that the vertical surfaces be parallel to the length of the boat.

FIBERGLASS: This is made easy by using the internal wooden structure located at the inner edge of the sponson as a guide. Use a permanent marker and a straightedge to mark the deck so that it is easier to see proper alignment. (Permanent markers wipe off with paint thinner; be sure to clean the boat before painting!) The straight trailing edge of the vertical wings should be flush with the rearmost part of the sponson.

ABS: Use a straight edge to draw a line on the deck which is parallel to the centerline of the boat. Use the front and rear edges of the “canoe” as the references. The straight trailing edge of the vertical wings should be flush with the rearmost edge of the sponson.

- ALL:** The rear uprights are attached to the deck with a 5° outward cant (see photo). Use 5-minute epoxy for this on the fiberglass hull, or JB Weld for ABS. It is necessary to roughen the surface of the deck slightly to improve adhesion. You should also roughen the glue surface on the wing.



To hold the surfaces in place while the epoxy is curing, use tape (electrical tape is recommended) to provide the necessary stability.

- 17) **FIBERGLASS ONLY:** The canard, or front wing, is attached to the hull so that the trailing edge is $\frac{3}{4}$ ” ahead of the tip of the cockpit. Make sure that the wing is perpendicular to the sides of the sponsons; the easiest way to do this is to measure the distance from the canard to the ram wing (center section of boat) and make it equal on both sides.

It can’t be stressed enough – for the boat to run properly, it is **EXTREMELY** important that the wing be parallel to the water when the boat is running. Any change will have major consequences when your boat is running 40+ MPH!

Set your boat on a flat surface in such a manner that the last few inches of the afterplane (from the back of the engine well to the transom) is level relative to the bottom of the sponsons. This is the desired attitude. One way to do this is to set the boat on a table top and use sheets of balsa to shim the afterplane to the correct height.

Test fit the wing (it should be pretty well finished by now, including priming) in the specified position fore/aft until it is a snug fit. Align the wing so that it is parallel to the table top, using a ruler to measure from the center of the leading and trailing edges to the table top. The wing should be located about ¼” below the deck. It is acceptable for the leading edge of the canard to be up to 1/16” closer to the table top than the trailing edge, but it is NOT acceptable for it to be any higher.

Once you are satisfied that the wing is perfectly parallel, CA it in place to tack it there. Use thickened 5-minute epoxy to attach it firmly to the hull. Thick epoxy will tend to make a nice fillet between hull and wing surface. Don't use too much epoxy here, as it only adds weight. You can round the fillet with your fingertip.

Once this cures, you are ready to begin final preparations for the finish and painting of your model.

FINISHING

The fiberglass UL1FG is made using standard epoxy resin, and is compatible with most modern finishing products and techniques. You will need to sand, fill (use automotive repair materials), prime, and paint the model according to the standard procedures recommended by your finish vendor. The prototype model was finished using Krylon, but others have since been finished with Pactra Formula U polyurethane with a Hobby Poxy clear top coat. The ABS hull may be finished with any plastic model paints, our favorite being Testors Model Masters (Guards Red for Pocket Mechanic, Bright Yellow for others).

Photos of the model and real boats are available on the RC-Hydros.com web site. Visit us at on the Internet to see how to decorate your boat according to a scale finish, or use the official photos available at www.ulrs.org.



For the 1999 season, the UL-125 was sold and started running as the UL-10. Documentation is available online for the UL-10 at several places including www.ulrs.org. Decals for the UL-10 in the “Earl’s Performance Products” setup are available from us as well.

The UL-125 is identical in design and construction to another boat, the UL-72 Pocket Mechanic (see photo below). Photos of the UL-72 are available on the Internet as well. It is a bright red boat with white trim. Cut vinyl decals for this scheme are available from RC-Hydros.com.



Our prototype Pocket Mechanic was finished using Model Masters brand enamel, in the Guards Red color. Two coats were applied over a base coat of Model Masters Classic White. Sanding between each coat was done with 1500-grit paper and water. After the final red coat, the decals were applied and the boat was sprayed with two coats of Hobby Poxy Gloss Clear top coat.

OPERATING

Since this boat is primarily intended for use by experienced boaters, it is expected that you will know how to configure your boat for optimal performance. If you have any questions, feel free to visit our website and drop an e-mail.

Before operating, please refer to the Safety Notes found on pages 2 and 3 of this manual.

Basic pointers

The prototype ran 10 laps on a 1/10th mile course using inexpensive 1500-size packs (\$25.00 retail) with the stock setup. After changing to an Octura X450, the speed increased tremendously and runtime was down to 6 laps. Extremely high speeds are possible with this boat when using a Cordite motor (available from RC-Hydros.com) and the proper setup. The Cordite motors require that the boat be set up with a rather shallow prop angle. An X637 seems to be the optimal prop in this configuration.

Note that use of Octura or Prather props requires an adapter available from RC-Hydros.com or from Hobby Lobby. Order part number GR2320.

Rudder Throw

Rudder throw was initially set to full travel right and 1/3 travel left. This gave adequate turn response for left maneuvers, but to prevent hooking at full speed the right travel was limited to about 50% when racing with the Cordite motor. The large Graupner rudder makes the boat very responsive to rudder input, and very stable. Alternate rudders, skid fins, and drive systems which work well are available from BBY Racing (www.bbyracing.com), Fullers Fast Electrics (www.drcwebservices.com/ffe), or from DPI (www.dpileisuresports.com).

Balance Point

Your boat should balance about 2" behind the sponson transom. This position will change as prop, rudder, and water conditions change, but this is a good starting point. Note that this boat is designed to be able to ride well with the bow high and not blow over, and with the tail high it still does not have a tendency to plow. The wide range makes the boat able to handle a variety of conditions without causing the racer problems.

When at the proper attitude, the back of the boat is just out of the water, riding on the prop.

More Stuff

If you are new to electric race boats, we seriously recommend that you purchase Jay Turner's book "Getting Started in Fast Electrics" published by Air Age (<http://www.airage.com>).

Got other questions? E-mail!